

The background features a soft-focus image of a white vase containing a large, feathery bunch of dried pampas grass. In the foreground, a round, shallow woven basket made of light-colored natural fibers sits on a white marble surface. The overall aesthetic is clean, minimalist, and bohemian.

THE ULTIMATE  
*interior design*  
CHEAT SHEET BUNDLE

MARIEROVIELLO.COM

## *Hi, I'm Marie!*

Do you feel overwhelmed just thinking about decorating your home? Trust me when I say that you're NOT alone. I totally get it...there are so many decisions to make when designing your home and it can feel like a lot to manage.



But with a little help, we can kick some of that design overwhelm to the curb.

At the end of the day, you just want to feel good about your home. It's really that simple. These handy cheat sheets are like having an interior designer on call. Feel confident when shopping and making updates to your home that you can refer back to these cheat sheets. If you have questions about paint or how high to hang that new art, remember that you can check here to get some quick answers. I'm SO happy to share a little bit of design love with you and I can't wait to hear how you transform your home.

Talk soon...

*Intuitive Interior Design*  
*Change your space, change your life.*



# 5 Quick Steps to Update Your Home

Want to do a quick "refresh" in your home? Here are some quick things you can do to give your home a new and improved look.

**1** Declutter your space to reduce the amount of "stuff" in the room. A cluttered space can make the room feel cramped and smaller. Clear out the clutter to make the space appear larger, cleaner and to create a more soothing space.

**2** Change up the paint color. Don't go crazy painting every room a totally different color. Use one or two colors throughout most of your home to create a smooth transition between rooms. Pick a neutral color you love and let the accents take center stage.

**3** Add new throw pillows to your sofa. New pillows give a totally different look and feel to a room without breaking the budget. You can change them up each season for a fresh look. Adding a throw or blanket also helps soften the room.

**4** Add an area rug to the room to bring in a fresh new color and personalize your space. An area rug can also anchor the furniture in that room. Choose a rug that coordinates with those throw pillows to give your room a totally new look.

**5** Hang some simple drapery panels to add softness and bring color and texture to your room. Drapery panels and other window coverings really give your room a finished look that ties the whole space together.

# Paint Finish Guide

Not sure what paint finish to use in your home?

Sherwin Williams, Benjamin Moore, and Farrow and Ball have beautiful paint colors. You can also buy paint at your local Home Depot. Look for low VOCs to be more ecofriendly.

## Flat

Little to no sheen and hides imperfections extremely well. Home builders often use flat paint as it's inexpensive and the easiest to touch up. It is also the least washable of all paints. Flat paint is best for ceilings.

## Matte

Reflects very little sheen to hide imperfections. It gives a soft, velvet finish to walls. Look for matte paints in an enamel finish to improve washability. Matte-enamel paint is my favorite paint choice for walls as it's washable with a velvet-like finish.

## Eggshell

Has a very light sheen that is more washable than matte or flat finishes. A great option for busy family homes or higher traffic areas.

## Satin

Higher sheen and durability than eggshell paint. It is easy to wash clean. It does not hide imperfections well so take care to prep surfaces carefully. Good for use on furniture, cabinets, trim and doors.

## Semi-Gloss/High-Gloss

The most durable and shiniest of the paint finishes. The high sheen makes it easy to clean but it will show all imperfections so careful surface prep is a must. Best for use on doors, trim, cabinets and bold design features to accentuate a space.

# Countertop Guide

Confused on what countertop to buy?

## Quartz, engineered countertops

An engineered product that combines crushed quartz and resin. Very durable and popular in recent years due to its consistent patterns and colorways. Stain and scratch resistant but avoid placing a hot pan from the oven on the counter as it could burn the resin and cause damage.

## Granite and quartzite

A natural and durable countertop choice. Due to its natural state, colorways and patterns aren't as consistent. Seal at installation to prevent staining. Sealant can be reapplied as necessary. Heat resistant and UV resistant. Quartzite is more prone to etching from acidic substances.

## Marble

A natural stone that is much softer and porous than granite or quartzite so care must be taken to avoid scratching, staining and etching. Best suited in bathrooms or low-use areas. If you want this look for your kitchen, look at quartz or porcelain slabs for better durability.

## Porcelain Slab

The "new kid" on the countertop block that is gaining in popularity. Veining is printed directly on the surface giving the look of natural stone. Porcelain is very durable-it's scratch, stain, and heat resistant. Not everyone is skilled to handle this newer product so be sure to find an experienced fabricator.

## Concrete

A durable choice with the option for lots of customization for colors, textures, edges, and finishes. Although concrete is a hard surface it is very porous so proper sealant is required to prevent staining. Hairline cracks can develop over time although there are additives to minimize that.

## Butcherblock

A softer countertop option that brings warmth to a kitchen. To prevent the wood from drying out, apply oil to the countertop periodically. Avoid placing hot pans directly on it as they could burn the wood. Nicks or gouges can be sanded out and re-oiled to restore the original appearance.

## Laminate

The most budget friendly option of all countertops since it's made from layers of paper and resin bonded together. It can scratch easily and is not heat resistant but it will give a smooth, clean look to a kitchen when budget is a factor.

# Guide to Hanging Art

You're finally ready to hang something on the wall-fantastic!! You can make sure it's the right size by cutting craft or wrapping paper to the size of your art and secure it to the wall with painter's tape. This is especially helpful when creating gallery walls.

## General Rule-60" from Floor

The center of the art should be 58-60" off the floor.

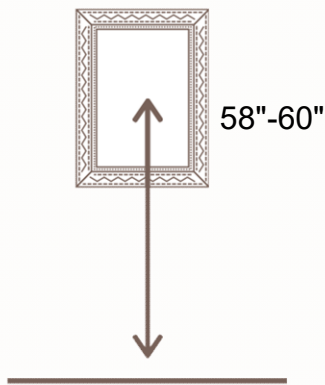

## Art Above Sofa-6"

Hang pieces about 6" above the sofa. You may need to go as low as 4" or as high as 8".

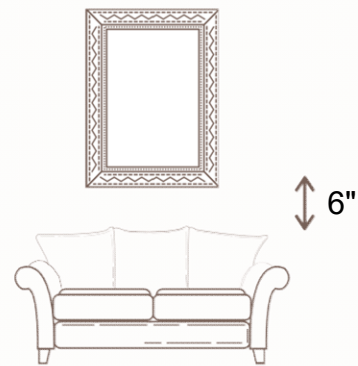

## Art Size Tip

Art should be about 2/3 the width of the furniture. Avoid hanging a tiny piece of art over a large piece of furniture or on a large wall.

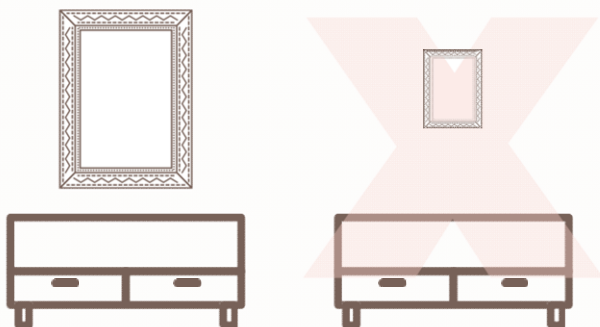

## Gallery Walls

Treat as one large piece of art. Follow above rules for hanging.

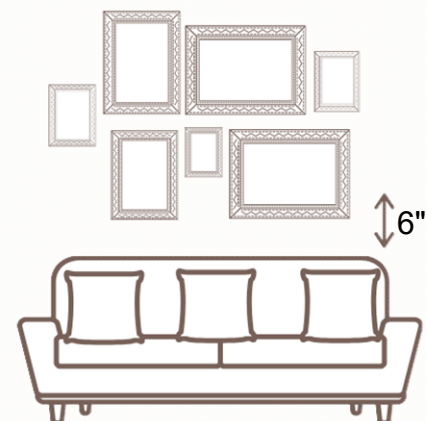

# Guide to Hanging Chandeliers

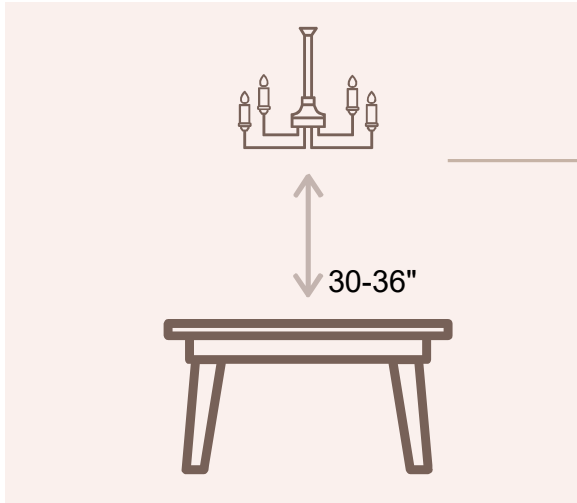

## 8' CEILINGS

For standard 8' ceilings a distance of 30-36" between the table and the bottom of the chandelier works best. Always consider the size of the room and table width when deciding on the final hanging height.

## 9' CEILINGS

Add 3" to the distance for each additional foot of ceiling height.

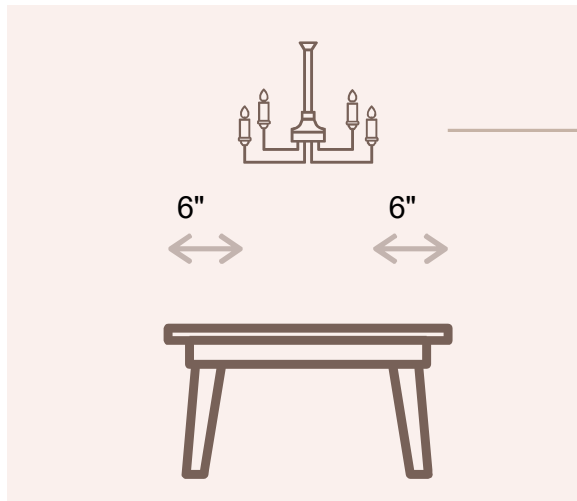
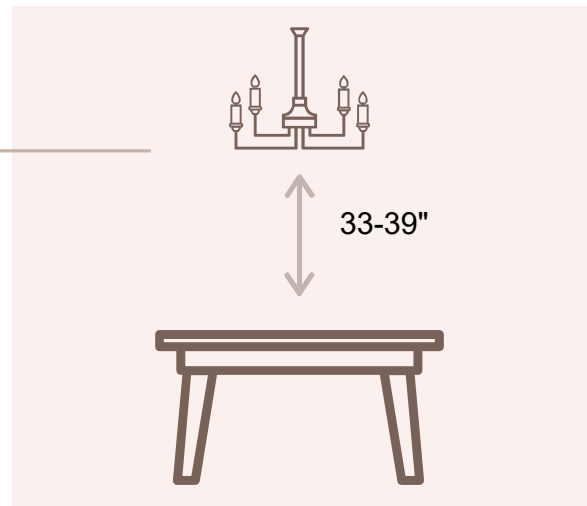

## CHANDELIER WIDTH

Make sure you have 6" on either side of the chandelier to the edge of the table so nobody bumps their head on the chandelier when sitting down.

# How to Style an End Table

When styling your end table remember the "Rule of Three." Groups of three are more interesting to look at so use three different objects on your end table. It's totally okay for a lamp to act as one of your objects (see example on the left).

The other important tip for end table styling is creating a visual triangle with your objects. You want objects at different heights so our eyes naturally have different places to look. As you choose decor for your end table make sure to include a mixture of tall, medium height, and shorter objects.

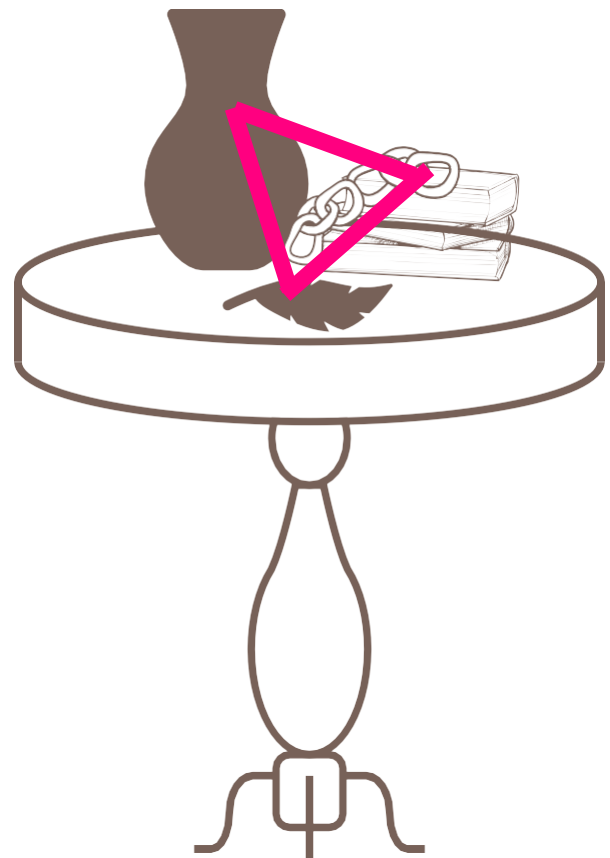
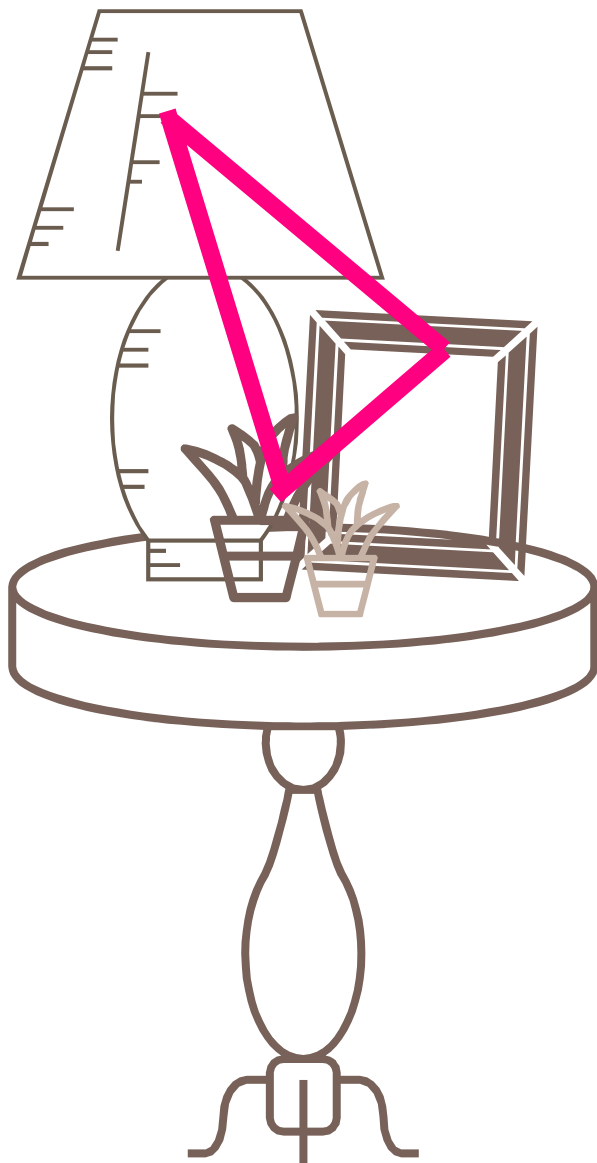



# How to Style a Console Table

Use a single, large accessory as a focal point if you aren't adding lamps.

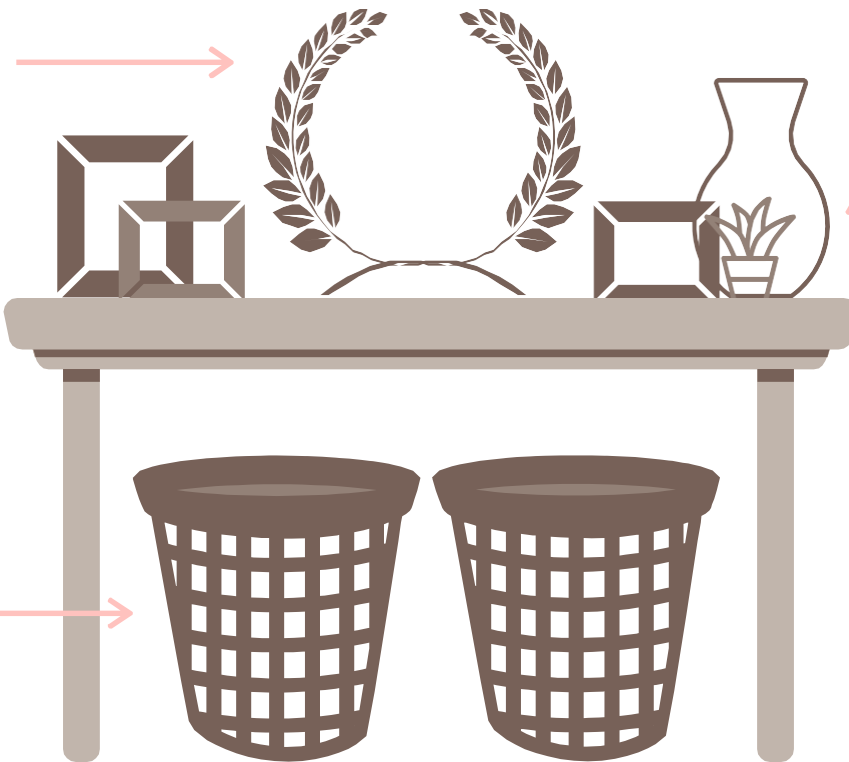

Add some accessories in groups of three.

Put a pair of baskets, poofs, or a small ottoman under open console tables



Depending on your table size you can use a single or pair of lamps

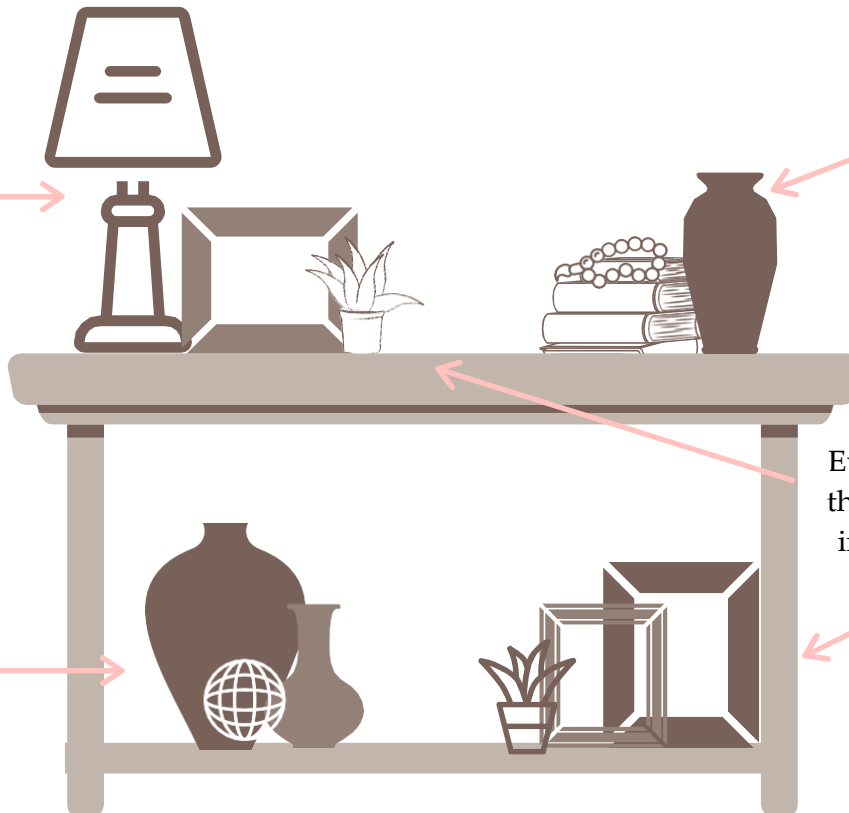

If you use a single lamp you can balance things out with a taller vase.

Stagger the height of the objects in your groups of three.

Even though the group of three frames is broken up into two areas, your eye travels to all of them.

# How to Style a Bookcase

Bookcase styling can be tricky so just be patient with it. Give yourself time and play around with different layouts until you find what you think looks the best.

When styling bookcases it's good to include a combo of pairs, trios, and single objects. It creates visual interest and gives a better end result that doesn't feel stuffy. It's also good to stagger your objects on shelves. If you have a single object on one shelf, be sure that the shelf above and below have a different number of objects.

Vases, urns, picture frames, baskets, interesting objects, books, spheres, plants/greenery, and beads are all great accessories for bookcases. Include objects with different textures to keep it interesting. Plain, stacked books can be used vertically or horizontally with objects placed on top to add height. Remember to be patient and have fun with it. You got this!

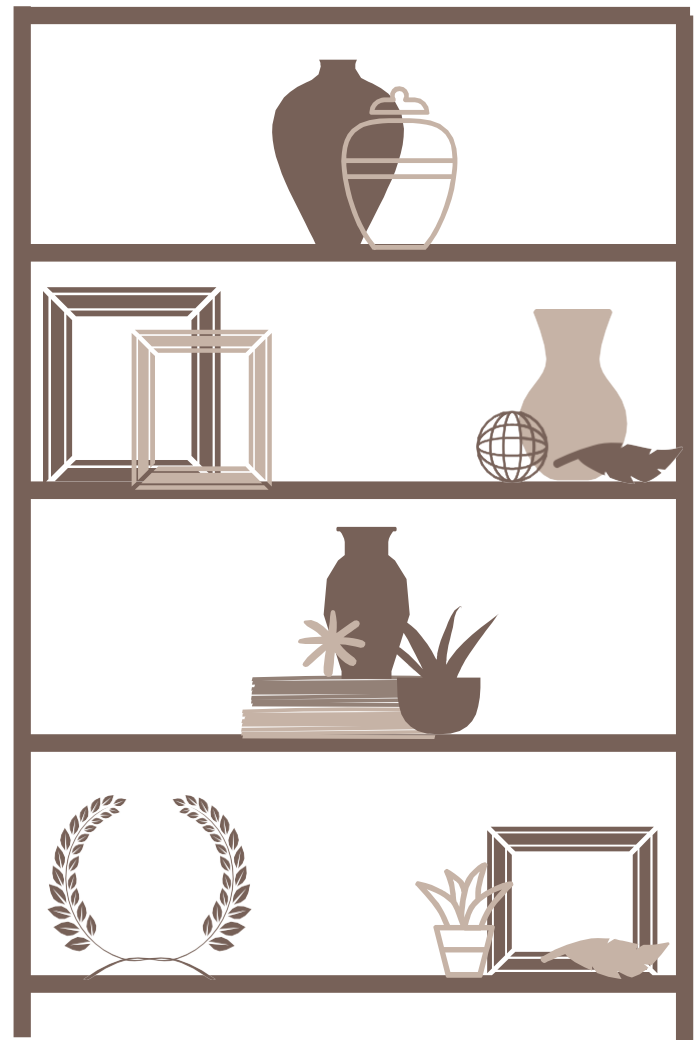
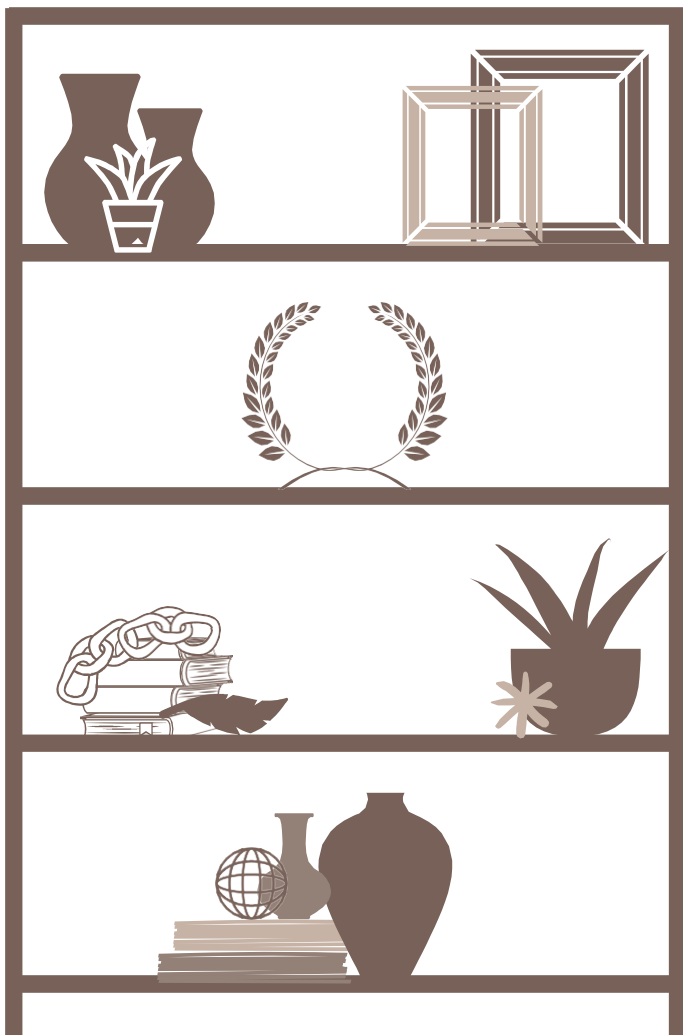

# How to Style a Coffee Table

(\*Most of these tips also apply to ottoman styling.)

There are lots of possibilities for coffee table styling. The key is to include objects of different sizes and textures.

First you want to add your larger items. I like to add trays to both coffee tables and ottomans. It gives a larger foundation to work with--especially for ottomans that lack hard surface areas. Stacked books can also act as your larger items. If you're using a tray on a coffee table, remember to also add objects to the side of the tray if you have room to do so. Everything doesn't have to be (and shouldn't be) on top of it. \*Note: with ottomans you'll have everything on the tray unless you add a throw to the side of the tray.

When styling your coffee table be sure to create a visual triangle of objects. You want something taller, something that's medium height, and something that's smaller. Vases, urns, interesting objects, books, spheres, plants/greenery, and beads are all great accessories for coffee tables.

Avoid adding picture frames to coffee tables. Somebody always sees the back of the frame which doesn't look good. So, save the frames for your end tables, console table or bookcase.

